

**NEW SPECIES AND CLADISTIC REANALYSIS OF
THE SPIDER GENUS *MONAPIA*
(ARANEAE, ANYPHAENIDAE, AMAUROBIOIDINAE)**

Martín J. Ramírez: Laboratory of Arthropods, Department of Biology, FCEyN, Universidad de Buenos Aires, Pabellón II Ciudad Universitaria (1428) Buenos Aires, Argentina, and Museo Argentino de Ciencias Naturales, Av. Angel Gallardo 470 (1405), Buenos Aires, Argentina

ABSTRACT. The known range of the South American genus *Monapia*, previously known only from temperate South American forests, is expanded to central and eastern Argentina and Uruguay. A monophyletic group of five species with spinose forelegs is proposed, including *M. angusta*, newly transferred from *Arachosia*, plus four new species: *M. charrua*, *M. guenoana*, *M. fierro* and *M. carolina*. One new species, *M. tandil* (from Buenos Aires Province), is proposed to be the sister group of *Monapia vittata*. A data matrix with 43 characters for the 13 species of the genus (plus 9 amaurobioidine outgroups) was cladistically analyzed. Although relationships among species are mostly resolved, the basal phylogeny of the genus remains unclear. The previous hypothesis of relationships of *Monapia alupuran* is unsupported in this new analysis. Additional records are given for *M. lutea* and *M. dilaticollis*.

The genus *Monapia* Simon 1897 was revised in a recent contribution (Ramírez 1995b). The seven species there included are endemic of the temperate forests of Southern Chile and adjacent Argentina. Mello-Leitão (1944) described *Arachosia angusta* from Buenos Aires, Argentina, a very peculiar species with elongate body, flat carapace and remarkably spinose forelegs. In recent years, two very similar undescribed species were collected on large riparian grasses from Buenos Aires and adjacent regions, and because of the highly modified body and bizarre leg spination they were thought to belong, together with *Arachosia angusta*, to a separate, undescribed genus. However, a reexamination of genitalic characters in *Arachosia angusta* and those two related species showed a depressed median area on the epigynum, a character previously considered as synapomorphic of *Monapia* (Ramírez 1995b), and the divided male conductor typical of that genus (i.e., Fig. 11). These species have extremely cryptic habits. Their elongate body helps camouflage the spiders on grass leaves, while the yellowish and spotted coloration mimics that of the dry leaves. *Monapia guenoana* new species females were found covering their eggsacs with their own body; and even when exposed to view, they were discerned with difficulty.

Besides these three elongate and very spinose spiders, I consider two more new species collected in grasslands of central Argentina. They also have spinose fore tibiae, but a typical amaurobioidine appearance. As shown below, these five species form a monophyletic group distributed in a region generically known as Pampas, where the main plant communities are grasslands. Finally, I include one new species close to *Monapia vittata* (Simon 1884) which was previously considered the sister group of all other species of the genus. In the light of these additional taxa and several new characters, a cladistic reanalysis for all *Monapia* species was undertaken. This analysis challenges some of the conclusions of my previous revision.

METHODS

The format of the descriptions follows Ramírez (1995b). Spermathecae for scanning microscopy were treated as in Sierwald (1990). All measurements are expressed in millimeters.

Specimens are deposited in the following institutions: CAS = California Academy of Sciences (Charles Griswold); IRSN = Institut Royal des Sciences Naturelles de Belgique, Brussels (Louis Baert); MACN = Museo Argentino de Ciencias Naturales “Bernardino

Rivadavia," Buenos Aires (Cristina Scioscia); MLP = Museo de La Plata (Carola Sutton de Licitra, Luis Pereira); ZMK = Zoologisk Museum, Copenhagen (Henrik Enghoff).

CLADISTIC ANALYSIS

All characters considered in a previous revision (Ramírez 1995b) were taken into account. Some descriptive terminology was modified as in Ramírez (1995a). Multistate characters were considered additive when the states are interpreted as internested homologies. This is not intended to express any assumption on the evolution of characters, but merely reflect degrees of similarity (Lipscomb 1992; Goloboff 1997). Morphoclines were interpreted as internested homologies. Because this approach might be suspected by some authors as an unjustified assumption, additional runnings were made with all characters non-additive. This analysis produced identical trees and statistics, thus demonstrating that the obtained phylogeny does not depend on my interpretation of morphoclines. The root of the tree was placed according to the subfamilial analysis made in Ramírez (1995a). Anyphaeninae was used as a more distant outgroup. Because the relationships among the 32 genera of that subfamily are unknown (Brescovit 1997), most entries were coded as polymorphisms, according to the variability found throughout genera. The resolution of the outgroups changed slightly from the previous analysis of the genus (Ramírez 1995b), according to new knowledge of the genera related to *Amaurobioides* Hickman 1949 (Ramírez 1997).

Character 0: Body pattern, 0 = dark patches or uniform, 1 = dark spots on light background (Fig. 1). Character 1: Carapace outline, 0 = oval (Fig. 35), 1 = lengthened (Fig. 8). Character 2: Carapace height, 0 = normal, the posterior slope begins near the thoracic fovea (Fig. 24), 1 = flattened, the slope begins well behind the thoracic fovea (Figs. 7, 14). Character 3: Posterior eye row, 0 = procurved or straight, 1 = recurved. Character 4: Abdomen shape, 0 = oval, 1 = lengthened. Character 5: Number of retromarginal cheliceral teeth, 0 = two, 1 = three, 2 = four or more. The character is considered additive (corrected additivity from Ramírez 1995b). Character 6: Long ventral hairs on male palpal tibia, 0 = absent, 1 = present. Re-examined from Ra-

mírez (1995b) and scored as absent in *Monapia alupuran* Ramírez 1995 because the hairs in *M. alupuran* are shorter than those on *M. vittata*, and very similar to those in other *Monapia*. Character 7: Cymbial basal retro-lateral notch, 0 = absent, 1 = weak (Figs. 27, 36), 2 = strong (Ramírez 1995b: fig. 48). Some undescribed species that probably belong to *Oxysoma* Nicolet 1849 have a strong cymbial notch. Considered additive. Character 8: Tegulum with a deep notch occupied by the median haematodocha, 0 = absent, 1 = present. Character 9: Trajectory of sperm duct, 0 = parallel to tegular notch, 1 = with a curve near the apical margin of tegulum. Coding and internal step for *Oxysoma* as in Ramírez (1995b: character 8). Character 10: Shape of paramedian apophysis, 0 = thick, 1 = thin, 2 = long and very thin. Considered additive. Character 11: Amaurobioidine paramedian apophysis closely associated with median apophysis (Ramírez 1995a), 0 = absent, 1 = present. Character 12: Length of basal portion of embolus, 0 = short, 1 = very long. The intermediate state "long" considered in Ramírez (1995b) is here ignored because after the addition of new species the distinction between "short" and "long" is equivocal. Character 13: Shape of basal portion of embolus, 0 = cylindrical, 1 = flattened. Character 14: Extension of basal embolar unsclerotized area, 0 = absent or small, 1 = wide. The scoring of "small" as an intermediate state made in the previous revision is not used here because it is scored in character 12 state 1 (the basal portion of the embolus is defined by the presence of the unsclerotized area). The wide and folded unsclerotized membrane present in *M. lutea* (Nicolet 1849) and *M. huaria* Ramírez 1995 is instead very different from the basic pattern of embolar morphology. Character 15: Grooved primary conductor (Ramírez 1995a), 0 = absent, 1 = present. Character 16: Secondary conductor, 0 = present, 1 = absent. Character 17: Groove in secondary conductor, 0 = absent (Figs. 38–39), 1 = present. In most *Monapia* species the secondary conductor is divided by an unsclerotized area, and the groove remains on the prolateral portion. Character 18: Division of secondary conductor (Ramírez 1995b), 0 = entire, 1 = divided by an unsclerotized area (Fig. 11). Character 19: Unsclerotized area of secondary conductor with a lobe, 0 = absent, 1 = present. Char-

acter 20: Prolateral portion of the secondary conductor displaced towards the base of the embolus, 0 = apical, 1 = displaced (Figs. 37, 39). Character 21: Denticles on prolateral portion of the secondary conductor, 0 = absent, 1 = present (Fig. 37). Character 22: Retrolateral portion of the secondary conductor fused to tegulum, 0 = free (Fig. 16), 1 = fused (Fig. 10). Character 23: Denticles on retrolateral portion of secondary conductor, 0 = absent, 1 = present. Character 24: Shape of base of retrolateral portion of secondary conductor, 0 = thick, 1 = thin and wide. Character 25: Anterior pouch on median epigynal field, 0 = absent, 1 = present (Fig. 4). Character 26: Shape of epigynal anterior pouch, 0 = pit like (Fig. 13), 1 = transversal furrow (Fig. 19). *Monapia angusta* is scored as uncertain because the opening is circular but prolonged to the sides in a furrow between the median field and lateral lobes. Character 27: Cavities on epigynal anterior pouch, 0 = a single pit or furrow, 1 = two cavities (Figs. 5, 30). Character 28: Central depression on epigynal median field, 0 = absent, 1 = present (Fig. 4), 2 = vestigial. Polymorphic entries and non-additivity justified in Ramírez (1995b). Character 29: Median pouch on epigynal median field, 0 = absent, 1 = present (Fig. 12). Variable through individuals of *M. dilaticollis* (Nicolet 1849) (see Ramírez 1995b: figs. 35–39). The small foldings found on *M. angusta* (Fig. 22) and *M. fierro* new species (Fig. 4) might be homologous to the median pouch; the character is coded as uncertain for these species. Character 30: Position of epigynal lateral lobes, 0 = separate, 1 = contiguous, 2 = fused with a median suture, 3 = fused without suture. Considered additive. Character 31: Degree of fusion of proximal copulatory ducts, 0 = separate, 1 = fused with median wall, 2 = totally fused with common lumen. Considered additive. The “unpaired copulatory duct” considered in the previous analysis as an independent character is subsumed here in the state 2. Character 32: Copulatory plug in mated females, 0 = absent, 1 = present. *M. angusta* was coded uncertain because only one female is known, which lacks plug. Entries coded as absent are based on numerous specimens. Character 33: Shape of spermathecae, 0 = irregular, 1 = spherical or oval. Character 34: Shape of copulatory ducts, 0 = thick, outline of duct not well distinct from that of

spermatheca, 1 = thin at least on distal portion, well distinct from outline of spermatheca. Character 35: Shape of anterior copulatory ducts, 0 = narrow (Figs. 19, 34), 1 = wide (Ramírez 1995b: figs. 61, 79). Character 36: Thickness of walls of proximal copulatory ducts, 0 = thick, 1 = thin. Character 37: Length of female tibia + metatarsus III, 0 = longer than tibia IV, 1 = shorter than tibia IV, 2 = shorter than 75% of tibia IV. Considered additive. Character 38: One strong anterior spine on chelicerae, 0 = absent, 1 = present. Scored as polymorphic in *Oxysoma*, because the spines are absent in *Oxysoma valdiviensis* (Simon 1897) but present in some undescribed species. Character 39: Ventral spines on female palp, 0 = absent, 1 = present. Character 40: Prolateral/ventral spines on anterior femora, 0 = absent, 1 = one (Figs. 24, 32), 2 = several. *M. charrua* new species and *M. angusta* have an oblique line of thick setae (Figs. 7, 20) in similar position as the thick spines of *M. guenoana* (Fig. 14), with which are presumed to be homologous. Considered additive. Character 41: Number of ventral spines on anterior tibiae, 0 = three pairs or less, 1 = four pairs or more. Character 42: Thickness of ventral spines on anterior tibiae, 0 = normal, slender (Figs. 24, 32), 1 = strong (Figs. 7, 14, 20). Character 43: Apical ventral spines on anterior tibiae, 0 = present, 1 = absent.

The data matrix of Table 1 was analyzed under parsimony using implied weights (Goloboff 1993, 1995), using Pee-Wee version 2.5.1 (Goloboff 1996a). This program assigns lower weight to characters showing more homoplasy. Internal steps of characters were assigned as implied by polymorphic terminals with command *ccode=*. Polymorphisms in Anyphaeninae were not taken into account for this purpose, because in such large group most characters are polymorphic, and it seems improper to decrease the weight of characters because of variability in a group so distant.

A heuristic search of 100 independent Wagner trees, each followed by TBR branch swapping (command *mult*100;*) produced the same two trees in all replications, for any value of the constant of concavity *K* ($1 \leq K \leq 6$). A strict consensus of the two trees is shown in Fig. 6. The cladograms have a length of 79 steps, consistency index (for informative characters only) of 0.65, a retention index of 0.83, a fit (sum of implied weights)

Table 1.—Data matrix for *Monapia* species and outgroups. x = [01], y = [012], z = [02], ? = unknown, - = uncertain. Commands for additivity and internal steps: ccode = 7 9 29 38 * = I 9 *- , +5 7 10 30 31 37 40;

	1		2		3		4	
	01234	56789	01234	56789	01234	56789	01234	56789
<i>Anyphaeninae</i>	0000x	2000-	--XXX	00-0-	----	xxxxx-	x0x0x	xy000
<i>Coptoprepes</i>	00000	20010	--000	11-0-	---00	0--00	00000	00000
<i>Amurobioides</i>	00010	10010	--000	11-0-	---00	0--00	00000	00000
<i>Ferrieria</i>	00010	20010	00000	1110-	00100	0--00	00000	00000
<i>Arachosia</i>	00000	00010	11000	0110-	00000	11?00	00011	00000
<i>Sanogasta</i>	00000	00010	11000	0110-	00000	1000?	?0011	00000
<i>Gayenna</i>	00000	00010	00000	0110-	000x0	10000	00011	00000
<i>Liparotoma</i>	00000	00010	00000	0110-	00000	10000	00011	00000
<i>Oxysona</i>	10101	00z11	00000	0110-	100x0	10000	00011	000x0
<i>Tasatta</i>	10000	20011	00000	0110-	100x0	10000	00011	00000
<i>Monapia vittata</i>	10000	01211	00000	01010	11000	11010	00111	00000
<i>Monapia alpuran</i>	10000	00011	10000	01111	10000	11110	00111	00000
<i>Monapia dilatocollis</i>	10000	00011	10010	01111	00111	1101x	10111	00000
<i>Monapia silvatica</i>	10000	00011	00110	01110	00111	11120	21111	00000
<i>Monapia pichinahuel</i>	10000	00011	10110	01110	00101	11120	21111	00000
<i>Monapia huaria</i>	10000	00011	20111	01111	00110	110x0	32011	00000
<i>Monapia lutea</i>	10000	00011	20111	01111	00110	110x0	32011	00000
<i>Monapia charrua</i>	10101	00011	00000	01110	00101	10011	00111	00101
<i>Monapia guenoana</i>	11101	00011	00000	01010	1000?	11011	00111	00211
<i>Monapia angusta</i>	11101	0????	?????	?????	?????	1?01-	00?11	00211
<i>Monapia ferro</i>	10000	00111	00000	01110	00001	1111-	00111	00000
<i>Monapia carolina</i>	10000	0????	?????	?????	?????	11111	00111	00000
<i>Monapia tandil</i>	10000	00111	00000	01010	11000	?????	?????	??00?

of 346 for $K = 3$, and a rescaled fit of 0.76. The same data were analyzed under equal weights, with the program NONA version 1.5.1 (Goloboff 1996b), and produced identical results.

The string of commands *poly-;max;apol;* of Pee-Wee/Nona was used to list the unambiguous synapomorphies common to the 270 possible dichotomous trees corresponding to the equally parsimonious resolutions of the politomies of the two trees. A parsimony jackknifing analysis (Farris et al. 1996) was made in order to have an estimation of support for clades. This procedure evaluates the stability of each node to a particular perturbation of the data set, which is the deletion of a portion of the characters. Over many replications with randomly deleted characters, the frequency at which a given node is monophyletic gives a measure of the support of the node: strongly supported nodes are more likely to be found even in absence of part of the data. The parsimony jackknifing is preferred over bootstrapping, because it produces a more direct relation between group frequency and support (Farris et al. 1996: 114). It is also preferred over the Bremer support (Bremer 1994), because in the latter, the values are absolute differences of steps (or fit), and a given figure might be originated by widely different relations among supporting and conflicting characters (Goloboff 1996a).

During the jackknifing analysis, 200 pseudoreplications were made deleting randomly 30% of the characters each time, as implemented in the JAK and FQ programs of Pee-Wee. Because the purpose was to evaluate support instead of quick searches, a more exhaustive search was made in each replication, instead of the kind of Wagner tree proposed in the original description of the method (“a fast approximate procedure, similar to the *hennig* command of Hennig86” (Farris et al. 1996: 113)). This procedure yields a better sensitivity of the support measure (Goloboff pers. comm.). For each pseudoreplicate matrix a Wagner tree with randomized sequence of addition of taxa was calculated and submitted to extended (TBR) branch-swapping, saving up to 50 most parsimonious trees (command *search=;*). Clades with positive support have a jackknife frequency between 0.5 and 1.

DISCUSSION

As in the previous analysis (Ramírez 1995b), *Monapia* appears supported by four characters (clade h, char. 18, 26, 28 and 32), of which two (char. 18 and 32) are also present in some taxa not included in this analysis. Compared with the previous fully resolved cladogram of *Monapia* species, this new analysis, with additional taxa and characters, is a bit more ambiguous. The consensus tree has a basal tetrachotomy; the resolutions place either clade j or *Monapia alupuran* as sister group of clade n.

Monapia tandil new species and *M. vittata* (clade i) are united by the proclateral denticles on the secondary conductor (char. 21), and the loss of the groove on the same sclerite (char. 17). *M. vittata* was previously considered the sister group of all other species of the genus, but in the present analysis its relationships are uncertain (see clade i), as those of *M. alupuran*, previously considered as the sister group of clade n. Clade j is united by the spinose forelegs and the median epiginal pouch (char. 29, 40 and 41), and clade k by the presence of a double anterior pouch (char. 27), with a convergence in clade p and in *M. alupuran*. Clade l is supported by four homoplasious characters: the flattened carapace and elongate abdomen (char. 2 and 4) are convergent in *Oxysoma*, the absence of apical ventral spines on fore tibiae and the strong ventral tibial spines (char. 42 and 43) are convergent in several groups, of which *Liparotoma* Simon 1884 and *Ferrieria* Tullgren 1901 are here included. The very similar species *M. guenoana* and *M. angusta* are united in the strongly supported clade m by five characters: the elongate carapace (char. 1), short third leg (char. 37), cheliceral spine (char. 38), and several ventral femoral spines on palp (char. 39) and first leg (char. 40 state 2). Clades n–q are unchanged from the previous analysis, although there are slight changes in the characters supporting them: the fusion of the secondary conductor to the tegulum (char. 22) is added as support to the clade n, the lobe on the unsclerotized area of secondary conductor is ambiguously optimized in clade p, one unclear state was deleted from character 14, and two logically dependent characters were considered here as one (see char. 31 above).

Clades l–q are strongly supported, with a

jackknife frequency of 0.9 or greater. The rather weak support of clade k, might be related only to the circumstance that *M. carolina* new species is known only from females.

Some of the species here described have a small sclerite arising from behind the median apophysis. Its shape can be pointed and thin (Figs. 27, 39), or triangular, or the sclerite can be apparently reduced to an indistinct sclerotized area. *Tasata* Simon 1903 species have a lamellar sclerite in that position, but its homology is unclear in most amaurobioidine genera. I preferred not to score or name this structure until a more detailed study across more amaurobioidine genera is done. In *M. fierro* and *M. tandil* the sclerite is pointed and thin. If this character is added to the matrix the same cladograms are obtained.

Areas of distribution of *Monapia* species might be of interest for studies of vicariance biogeography. *M. vittata*, *M. alupuran* and clade n are endemic to temperate forests of southern Chile and adjacent Argentina. Most species of clade n are sympatric. Only the sister species *M. lutea* and *M. huarua* appear to have non-overlapping distributions (Ramírez 1995b: 87): *M. lutea* ranges from Curicó Province to Chiloé, while *M. huarua* was found only in Valparaíso Province and around Santiago city. Clade l is endemic to riparian areas of eastern Argentina and Uruguay. *Monapia carolina* was found in central Argentina, where no other *Monapia* species lives. *M. fierro* and *M. tandil* are endemic to grasslands of east-central Argentina. Perhaps the most peculiar distribution is that of *M. vittata* and *M. tandil*, a pair of sister species known from widely disjunct areas. However, these data might change when additional specimens of *M. tandil*, known only from one individual, are collected. The cladogram presented here does not suggest a specific hypothesis of area relationship at both sides of the Andes because of the lack of resolution of the polytomy h: the six possible dichotomous resolutions propose mutually exclusive relationships of areas.

Monapia Simon 1897

Monapia Simon 1897: 93, 96, 97, 101. Gerschman de Pikelin & Schiapelli 1970: 131. Ramírez 1995b: 78.

Synonymy, diagnosis and description given in Ramírez 1995b.

Monapia charrua new species

(Figs. 7–13)

Types.—Female holotype (MACN 9576) and male paratype (MACN 9577) from Argentina, Entre Ríos Province, Río Gualaguaychú and RN 14, 14 July 1985, M. Ramírez.

Etymology.—The specific name is a noun in apposition taken from the Charrúas, an indigenous ethnic group that lived in the region where this species occurs.

Diagnosis.—Males, females and juveniles resemble those of *M. angusta* and *M. guenoana* by having an elongate body, but are distinguished by the chelicerae lacking spines.

Female (holotype).—Total length 6.63. Carapace 2.52 long, 1.68 wide, wider between coxae II–III. Length of tibiae/metatarsi: I missing; II 2.16/1.76; III 1.40/1.24; IV 2.72/2.72. Palpal tarsus 0.90 long. Sternum 1.50 long. Spines (female from Rosario del Tala): Leg I: Femur d 1-1-1, p 0-0-d1-1-d1 and an apical oblique line of thick setae (Fig. 7), r 0-d1-d1; tibia v 2-2-2-2-0, p and r 1-1; metatarsus v 2-2-2-0, p and r 1-0, d 0-p1-2. II: Femur d 1-1-1, p and r 0-1-1; tibia v 2-r1-2-0-2, p 1-1, r 1-v1; metatarsus v 2bas, p d1-1-0-1, r d1-v1-0-1, d p1-2. III: Femur d 1-1-1, p 0-1-1, r 1ap; tibia v p1-p1-2, p and r d1-1, d r1-1; metatarsus v 2-0-2, p and r d1-1-1, d p1-2. IV: Femur d 1-1-1, p and r 1ap; patella r 1; tibia v p1-2-2, p and r 1-1, d r1-1; metatarsus v 2-2-2, p, r and d = III. Palp: Femur ventrally with median line of 8 spines, d 0-0-1-p2, p 1ap; patella p 2-0, d 1-0-1; tibia p 2-2, d 1-1; tarsus v 2ap, p 1-1, r 1-0, d 2bas. Color: yellow with brown spots on the dorsal axis of body and sparse spots on dorsum (Fig. 8) and legs. Chelicerae with anterior longitudinal brown spot. Epigynum with anterior pouch wide, almost hemispherical, lateral lobes separate, median depression large, extended behind the anterior pouch (Fig. 12), usually occupied by a massive plug. Copulatory ducts with thick walls, accessory bulb with long duct parallel to margin of lateral lobes (Fig. 13).

Male (paratype).—Total length 4.12. Carapace 1.98 long, 1.28 wide. Abdomen 2.30 long. Length of tibiae/metatarsi: I 2.40/2.02; II 1.80/1.54; III 1.18/1.04; IV 2.06/2.22. Spines: Leg I: Femur d 1-1-1, p 0-0-d1-1-d1 and an apical oblique line of thick setae, r d1ap; tibia v 2-2-2-2-0, p and r 1-1; metatarsus v 2-2-2-0, p and r 1-0, d 0-p1-2. II: Femur

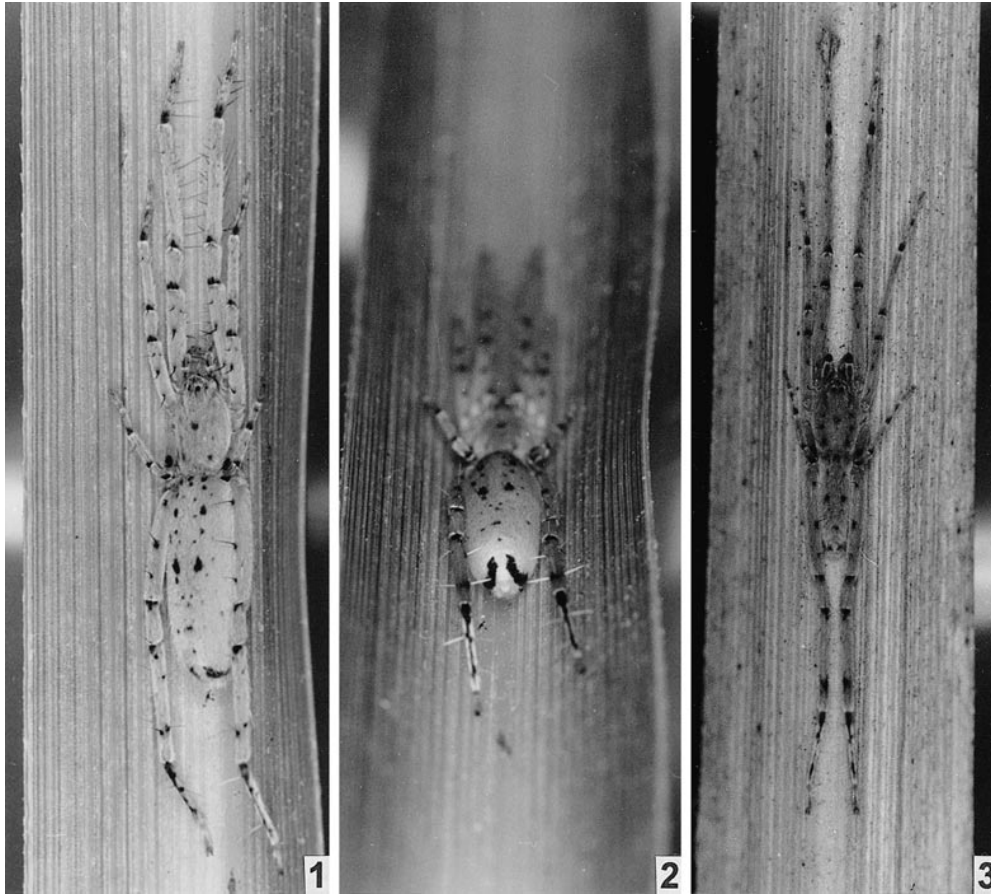

Figures 1–3.—*Monapia guenoana* new species. 1, Female on leaf of *Panicum prionitis*; 2, Same, posterior view; 3, Male.

d 1-1-1, p 0-d1-d1, r dlap; tibia v 2-r1-2-0, p and r d1-1; metatarsus v 2-r1-r1, p and r d1-1, d 0-p1-2. III: Femur = II; tibia v p1-p1-2, p and r d1-1, d r1-1; metatarsus v 2-0-2, p and r 0-d1-1, d 0-p1-2. IV: Femur d 1-1-1, p and r dlap; patella r 1; tibia v p1-2-2, p and r d1-1, d r1-1; metatarsus v 2-2-2, p and r d1-1-1, d 0-p1-2. Palp: Femur d 0-0-1-2, p dlap; patella p d2, d 1-0-1; tibia p 2-2, d r1-1; cymbium p 1-1-1, d 2-0. Color: as in female but darker. Copulatory bulb (Figs. 9–11) with paramedian apophysis sinuous, embolus long and thick, retrolateral portion of secondary conductor fused to tegulum.

Natural history.—Most specimens were collected on the large grass *Panicum prionitis* (“paja brava”) in temporarily flooded riparian areas, in close sympatry with *Monapia guenoana*.

Distribution.—Riparian zones of Entre Ríos Province in Argentina and Departamento Rocha in Uruguay.

Other material examined.—**ARGENTINA:** *Entre Ríos:* Same locality as types, 1♂1♀ (MACN); Gualeguay, 20 August 1989, M. Ramírez, 1♀ (MACN); Rosario del Tala, 20 November 1988, M. Ramírez, 1♀ (MACN). **URUGUAY:** *Departamento Rocha:* Arroyo Sarandí del Consejo, ruta 9 km 251, 18 May 1993, M. Ramírez & F. Pérez Miles, 1♂3juv. (MACN).

Monapia guenoana new species
(Figs. 1–3, 14–19)

Types.—Female holotype (MACN 9578) and male paratype (MACN 9579) from Argentina, Entre Ríos Province, Gualeguay, 20 August 1989, M. Ramírez.

Etymology.—The specific name is a noun

in aposition taken from the Guenoanes, an indigenous ethnic group related to the Charrúas, that lived in the region where this species occurs.

Diagnosis.—Males, females and juveniles resemble those of *M. angusta* and *M. charrua* by having an elongate body, but are distinguished by the anterior legs with several ventral spines on femora (Fig. 14), and numerous (more than 7 pairs) strong ventral spines on tibiae.

Female (holotype).—Total length 6.95. Carapace 2.38 long, 1.46 wide, wider on coxa II. Length of tibiae/metatarsi: I 2.96/1.54; II 1.60/1.04; III 0.90/0.68; IV 2.76/2.08. Palpal tarsus 0.80 long. Sternum 1.38 long. Spines: Chelicerae with 1 strong basal anterior. Leg I (Fig. 14): Femur d 1-1-1, p 1 ap, v 2-2-2-2ap or 2-2-2-2-r1-r1-r1ap; tibia ventrally with a prolateral line of 10 or 11, and a retrolateral of 13 or 14; metatarsus v 2-2-2-0, p y r 1 ap. II: Femur d 1-1-1, p and r 1 ap; tibia v r1-r1-r1-2-0; metatarsus v 2-r1-r1, p 0-1-d1, r d1ap. III: Femur = II; tibia v p1-p1-0, p 1-1, r 0-1, d r1-0-1; metatarsus v r1-0, d 2ap, r 1ap. IV: Femur d 1-1-1, p 0-1; tibia v p1-2-r1, p and r 1-1, d r1-0-1; metatarsus v 2-p1-0, p 2-0-1, r 1-1-2. Palp: Femur ventrally with median line of 4 or 7, d 0-0-1-1, p 1ap; patella d 1ap, p 2bas; tibia p 3-2, d 1-1; tarsus d 2bas, p 1, v 2ap. Color: yellow, with dorsal pattern of brown spots (Figs. 1, 2) and two dark parallel patches at each side of spinnerets. Legs with spots as follows: femora I-IV d 1-1-1-1, III p v1ap; patellae I-IV d 3-1, III v p1 wide; tibiae I-III d 1bas, IV d 1-1, p 0-1, r 1-0; metatarsi I-III d 1-1, IV with a longitudinal band, basally wider. The terminal dark spots on abdomen and the lines on hind metatarsus are conspicuous from above when the spider is at resting position (Fig. 2). Epigynum with anterior pouch wide, lateral lobes separate, median area depressed behind the anterior pouch (Fig. 18), copulatory openings usually occupied by one plug each. Copulatory ducts with thick walls, duct of the accessory bulb curved in a transversal plane (Fig. 19).

Male (paratype).—Total length 3.20. Carapace 1.80 long, 1.16 wide. Abdomen 2.08 long. Length of tibiae/metatarsi: I 2.84/1.78; II 1.54/1.02; III 0.80/0.64; IV 2.48/1.88. Spine arrangement similar to female, but much weaker. Ventral foreleg spines thin and not erect. Color: as in female; some individuals

have dark first tibiae. Copulatory bulb (Figs. 15–17) with paramedian apophysis sinuous, embolus short and thick, with basal membrane extending half of its length, retrolateral portion of secondary conductor small, with a ventro-basal peak, prolateral portion without groove, displaced towards the base of embolus.

Natural history.—Specimens were collected at the bases of the large grass (1.5–2 m tall) *Panicum prionitis* (“paja brava”) in temporarily or permanently flooded riparian areas. In some localities they occur in close sympatry with *Monapia charrua*. Females make a flattened egg-sac on the concave side of the leaves, and the egg-sac is covered by its cryptic body. The grasses where the spiders live have thin, quite rigid and straight leaves, with a V-section. The spider uses to walk along the concavity of the leaf keeping its legs I, II and IV aligned with the body and leaf axis (Figs. 1–3). While doing this, the forelegs are usually not used to walk, but to palpate the substrate, and the articulations femur-patella of legs II and IV are almost not moved. In these legs the movements are mostly achieved by the tibia-metatarsus joints.

Distribution.—Riparian zones of Entre Ríos and northeast of Buenos Aires Provinces in Argentina, and Departamento Rocha in Uruguay.

Other material examined.—**ARGENTINA:** *Entre Ríos:* Same data as the types, 2♀ (MACN); Arroyo El Palmar and RN 14, 14 October 1984, M. Ramírez, 1♀ (MACN); Arroyo Gualayán and RN 14, near Gualaguaychú, 2 November 1996, M. Ramírez 2♂2♀ (MACN); Río Gualaguaychú and RN 14, 10 December 1982, M. Ramírez & P. Goloboff, 3♀ (MACN); Rosario del Tala, 20 November 1988, M. Ramírez, 3♀ (MACN). *Buenos Aires:* Delta, estación experimental INTA, July 1968, A. Bachmann, 1♀ (MACN); Isla Talavera, 2 km E Zárate, 3 November 1996, M. Ramírez 1♂4♀ (MACN). **URUGUAY:** *Departamento Rocha:* Arroyo Sarandí del Consejo, ruta 9 km 251, 18 May 1993, M. Ramírez & F. Pérez Miles, 1♀3juv. (MACN).

Monapia angusta (Mello-Leitão 1944) **new combination**
(Figs. 20–23)

Arachosia angusta Mello-Leitão 1944: 357 (juvenile holotype from Argentina, Buenos Aires Province, Tigre, Río Guayracá, MLP 16100, examined).

Note: The holotype is a badly preserved and slight-

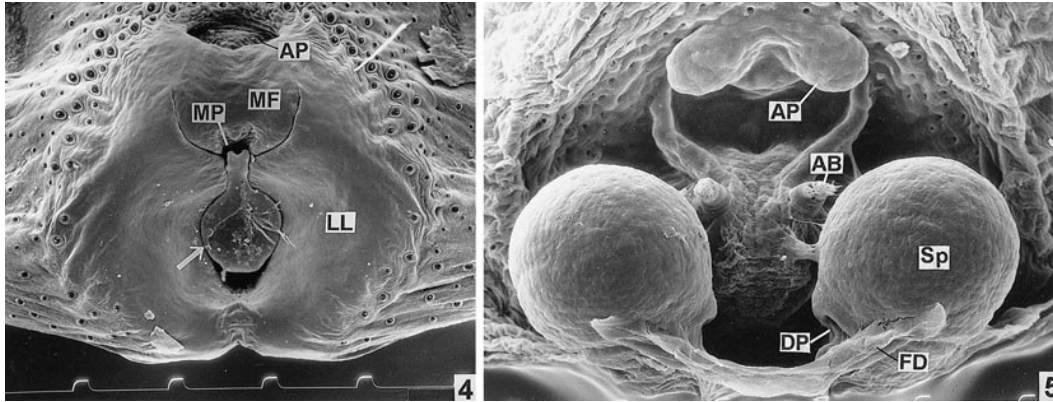

Figures 4–5.—*Monapia fierro* new species. 4, Epigynum (arrow indicates the copulatory plug on median depression); 5, Vulva, dorsal. (AB = Accessory bulb. AP = epigynal anterior pouch. DP = “dicytnoid” pore of spermatheca. FD = fertilization duct. LL = epigynal lateral lobe. MF = epigynal median field. MP = epigynal median pouch. Sp = spermatheca.)

ly crushed juvenile. Although the cheliceral spines are lost, their insertions are clearly visible, as well as the ventral spines on the foreleg.

Diagnosis.—Females and juveniles resemble those of *M. guenoana* by having an elongate body and basal anterior spines on the chelicerae, but can be distinguished by having only 4 pairs of ventral spines on the anterior tibiae.

Female (Mar del Tuyú).—Carapace damaged, bowed, ≈ 2.50 long, ≈ 1.70 wide. Abdomen elongated, deformed. Length of tibiae/metatarsi: I 3.40/2.48; II 2.26/1.64; III 1.28/1.20; IV 3.32/2.56. Palps long (Fig. 20), palpal tarsus 1.30 long. Sternum 1.44 long. Spines: Chelicerae with 1 strong basal anterior. Legs I: Femur d 1-1-1, p 0-0-v1-d1 and an apical oblique line of thick setae, r 1ap; tibia v 2-2-2-2-0, d r1-1 setae; metatarsus v 2-2-2-0-0, d p1-p1-r1-0-2. II: Femur d 1-1-1, p 0-1-1, r 1ap; tibia v 2-r1-2-r1-0, p 1-1, d r1-1 setae; metatarsus v 2-r1-r1, p 1-0, d p1-2. III: Femur = II; tibia v p1-p1, p 0-1, d r1-1; metatarsus v 2-0-p1, d p1-2. IV: Femur d = I; tibia v 2-p1-r1, p and r 1-1, d r1-1; metatarsus v 2-p1-p1, p 1-1, r 0-1, d 2-2-2 or 2-p1-2-2. Palp: Femur with ventral and prolateral lines of several spines, d 0-0-1-1-1, p 0-1; patella p 2-3, d 1-1; tibia with a ventral line of slender spines, p 3-1-d1-0-0, d 1-1-0; tarsus v 2-2-2, d p2bas. Color (immature from Castillos, Fig. 21): yellow, with dark reddish-brown spots on legs and dorsum; abdomen with dorsal white guanine reticulum under cuticle. Epigynum

with lateral lobes widely separated, median field depressed in the center and behind the lateral lobes, folded in its anterior half and elevated over the anterior pouch (Fig. 22). Anterior pouch with spherical cavity; the opening is prolonged on each side in the anterior border of the median field. Spermathecae oval, accessory bulbs with long and sinuous ducts (Fig. 23).

Male.—Unknown.

Natural history.—The specimens were collected on Pampas grass *Cortaderia seloana* (“cortadera”).

Distribution.—Margins of Río de La Plata and Paraná in Buenos Aires and Uruguay.

Other material examined.—**ARGENTINA:** Buenos Aires: Mar del Tuyú, February 1984, M. Ramírez 1♀ (MACN); Paraná de las Palmas, 7 April 63, M. Galiano, 2juv. (MACN); Reserva Otamendi, 10 June 1997, M. Ramírez, L. Compagnucci, C. Grismado, F. Uehara, 1juv. (MACN). **URUGUAY:** *Departamento Rocha:* Laguna de Castillos, 19 May 1993, M. Ramírez & F. Pérez Miles, 4juv. (MACN).

Monapia fierro new species
(Figs. 4, 5, 24–30)

Types.—Female holotype (MACN 9580) and male paratype (MACN 9581) from Argentina, Buenos Aires Province, Sierra de la Ventana, Cerro Negro, April 1974, Cesari.

Etymology.—The specific name is dedicated to the brave gaucho Martín Fierro, who

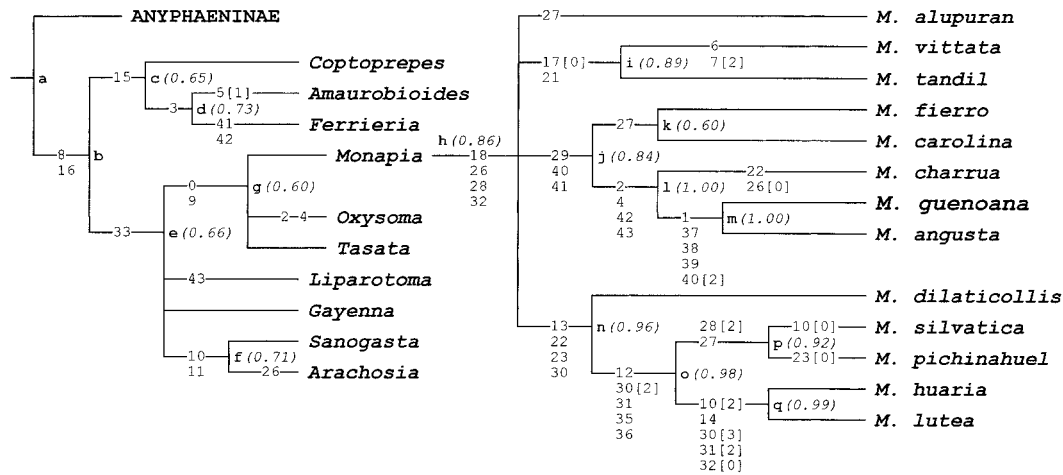

Figure 6.—Cladogram of *Monapia* species and outgroups. Unambiguous synapomorphies are noted on branches, character states are "1", otherwise noted in brackets. Jackknife frequency for each clade noted in parenthesis.

gives the name to the most popular Argentinian poem, written by José Hernández.

Diagnosis.—This species is most similar to *M. carolina*, but females can be distinguished by the wider opening of the anterior epigynal pouch; furthermore, they usually have 5 pairs of ventral spines on anterior tibiae. Males are recognized by the short and thick embolus.

Female (holotype).—Total length 6.00. Carapace 2.88 long, 2.10 wide, wider on coxae III. Length of tibiae/metatarsi: I 2.06/1.72; II 1.80/1.60; III 1.54/1.58; IV 2.20/2.56. Palpal tarsus 1.00 long. Sternum 1.50 long. Spines: Legs I: Femur d 1-1-1, p 0-0-1-d1, r 1ap; tibia with two lines of ventral spines, 4 or 6 prolateral, 5 retrolateral, (most commonly 2-2-2-2-0-2), p 1-1, r 0-1; metatarsus v 2bas, p and r 1, d 0-p1-2. II: Femur d 1-1-1, p and r 0-1-1; tibia v 2-2-2-0-2 or 2-2-2-2-2, p 1-1, r 0-1; metatarsus = I. III: Femur = II; patella r 1, d 1ap; tibia v p1-2-2, p and r 1-1, d r1-1; metatarsus v 2-0-2, p and r 1-1, d 2-p1-2. IV: Femur d 1-1-1, p and r 1ap; patella r 1, d 1ap; tibia = III; metatarsus v 2-2-2, p and r 1-1, d 2-p1-2. Palp: Femur d 0-0-1-2, p 1ap; patella d 1-1; tibia p 2-2, d 1-1; tarsus v p2ap, p 1-1, r 1-0, d 2bas. Color: light brown, legs with brown spots, dorsum with brown pattern as in Fig. 25, sternum with three spots on each side, abdomen ventrally with three longitudinal brown stripes from epigastric furrow to the spiracle. Epigynum with central depression, lateral lobes with internal border sinuous, al-

most touching on middle (Figs. 4, 29); median field elevated below anterior pouch, central depression prolonged in small foldings above central depression. Anterior pouch with two-fold cavity (Figs. 5, 30). Accessory bulbs with vertical ducts. Central epigynal depression often occupied by hard plug (Fig. 4).

Male (paratype).—Total length 5.41. Carapace 2.52 long, 1.90 wide. Abdomen 2.80 long. Length of tibiae/metatarsi: I 1.98/1.70; II 1.68/1.48; III 1.40/1.40; IV 1.98/2.20. Spines distributed as in female but weaker. Color: as in female. Cymbium with slight retrolateral basal notch. Copulatory bulb (Figs. 26–28) with paramedian apophysis short and thick, embolus short and thick, with basal membrane extending half of its length, retrolateral portion of secondary conductor with long and thin tip and small ventro-basal peak. There is a thin pointed sclerite of uncertain homology arising behind the median apophysis.

Natural history.—Specimens were collected in white retreats in bunches of grass.

Distribution.—Known from grasslands in Buenos Aires and eastern Chubut Provinces.

Other material examined.—**ARGENTINA:** *Chubut:* Isla de los Pájaros, Golfo de San José, 10 August 1975, M. Rumboll, 3 ♀ (MACN); Península de Valdez, Punta Norte, 2 August 1972, M. Rumboll, 1 ♀ (MACN). *Buenos Aires:* same locality as types, 2 ♂ 2 ♀ 1 juv. (MACN); Allen, August 1945, Conciotti, 1 ♀ (MLP); Argerich, Villarino, June-July

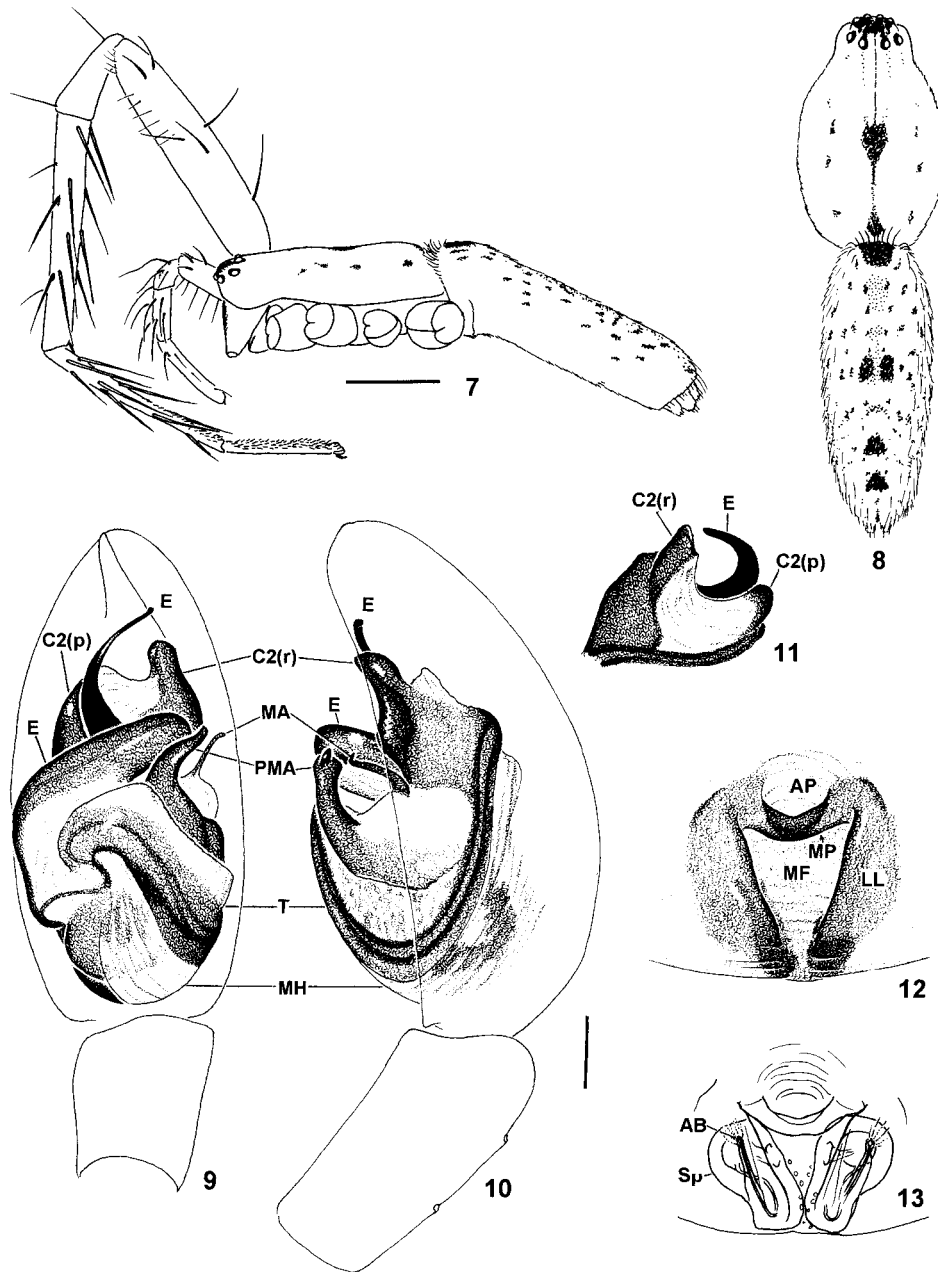

Figures 7–13.—*Monapia charrua* new species. 7, Female, lateral, 8, Female, dorsal; 9, Male palp, ventral; 10, Palp, retrolateral; 11, Palp, apical detail; 12, Epigynum, ventral; 13, Epigynum, dorsal, cleared. *Abbreviations:* AB = Accessory bulb of spermathecae; AP = epigynal anterior pouch; C2(p) = prolateral portion of the amaurobioidine secondary conductor; C2(r) = retrolateral portion of the amaurobioidine secondary conductor; E = embolus; LL = epigynal lateral lobe; MA = median apophysis; MH = median hematodocha; MF = epigynal median field; MP = epigynal median pouch; PMA = amaurobioidine paramedian apophysis; Sp = spermatheca; T = tegulum. *Scales:* Figs. 7–8 = 1 mm, Figs. 9–13 = 0.1 mm.

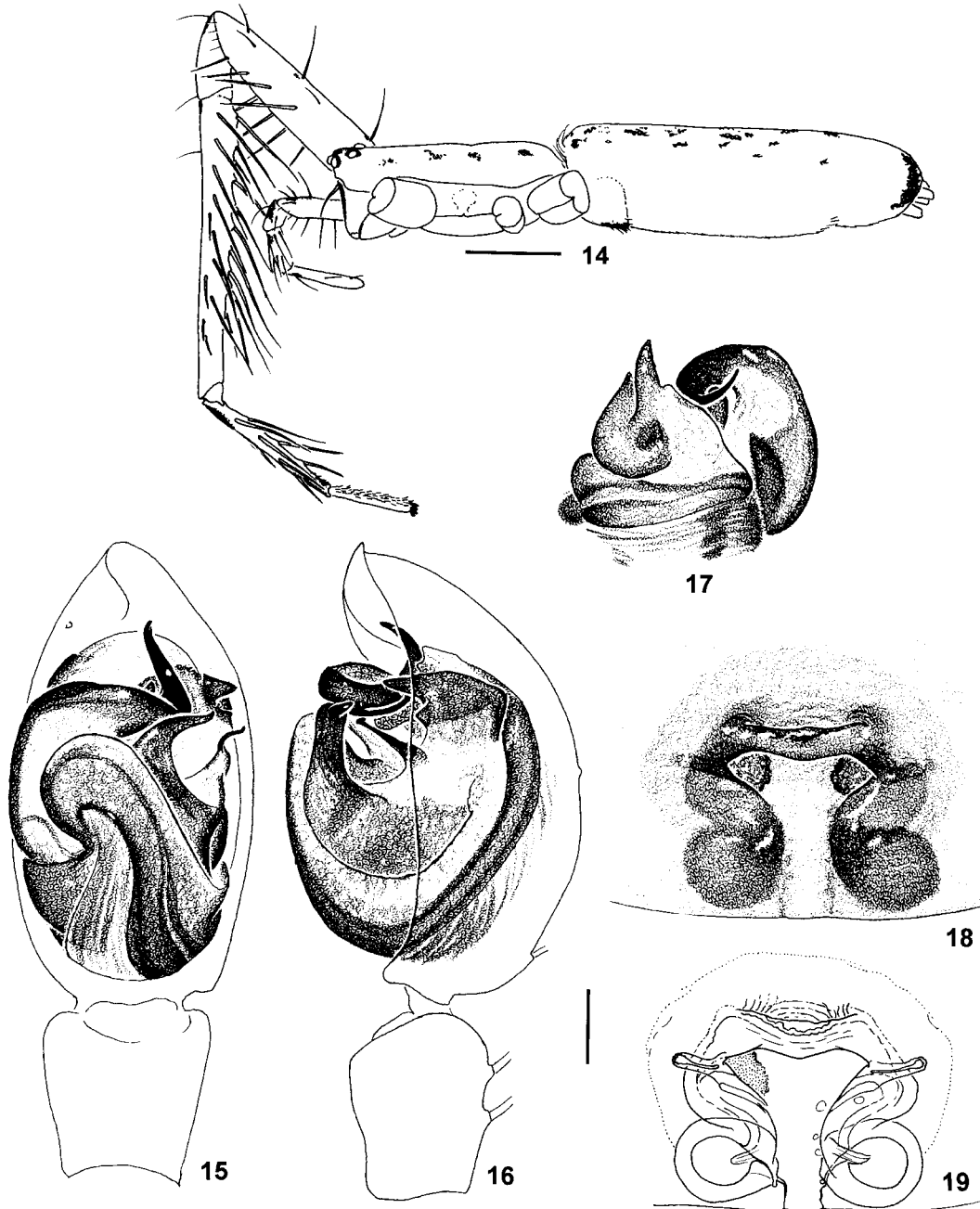

Figures 14–19.—*Monapia guenoana* new species. 14, Female, lateral; 15, Male palp, ventral; 16, Palp, retrolateral; 17, Palp, apical detail; 18, Epigynum, ventral; 19, Epigynum, cleared. Scales: Fig. 14 = 1 mm, Figs. 15–19 = 0.1 mm.

1958, H. Hepper, 2 ♀ (MACN); Brandsen, no date, M. Birabén, 1 ♀ (MLP); D'Orbigny, November 1963, J.M. Gallardo, 1 ♀ (MACN); 15 Km W Lobería, 4 September 1972, 1 ♀ (MACN); Las Flores, 24 May 1931, J.M. Daguerre, 5 ♂ 14 ♀ (MACN

29951); Los Médanos, 8 April 1965, J.M. Gallardo & E. Maury, 2 ♂ 5 juv. (MACN); Mar del Plata, 20–21 July 1984, M. Ramírez, 8 ♀ (MACN); Mar del Tuyú, 2 May 1981, M. Ramírez, 1 ♂ (MACN); Olavarría, Sierra de la China, 19 November 1965, E.

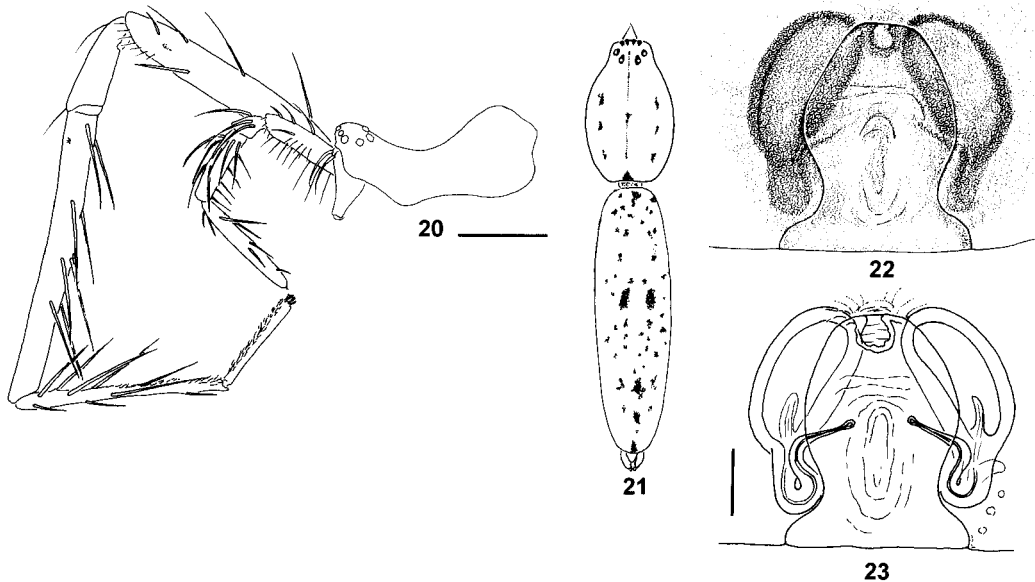

Figures 20–23.—*Monapia angusta* (Mello-Leitão). 20, Female, lateral; 21, Immature from Castillos; 22, Epigynum, ventral, 23, Epigynum, cleared. Scales: Figs. 20–21 = 1 mm, Figs. 22–23 = 0.1 mm.

Maury, 3♀ 1juv. (MACN); Otamendi, 20 October 1979, P. Goloboff, 1♀ (MACN); Quequén, 7–12 May 1931, J.M. Daguerre, 1♂6♀ (MACN 28871), June 1931, J.M. Daguerre, 1♂1♀ (MACN), 1941, E. Balech, 1♂ (MACN); Río Luján, estación FCGM, 14 November 1991, Pesce, 1♀ (MACN); Rosas (?), F.C.S., 2♀ (MACN); between Tres Arroyos and Pringles, November 1962, M.E. Galiano, 4♀ (MACN); Sierras de Azul, 1–2 October 1983, P. Goloboff & A. Zanetic, 1♀ (MACN); Sierra de la Ventana, Pque. Prov. E. Tornquist, 18–20 November 1982, M. Ramírez, 5♀ (MACN); October 1988, M.E. Galiano & C. Scioscia, 1♀ (MACN); Sierra de los Padres, 27 October 1984, M. Ramírez, 10♀ (MACN); Tandil, J.M. Viana, many ♂♀ (MACN); Tornquist, estación Fortín Chaco, January 1972, J. Arias, 1♀ (MACN).

Monapia carolina new species
(Figs. 31–34)

Types.—Female holotype (MACN 9582) from Argentina, San Luis Province, Carolina, September 1970, J.M. Viana & Williner.

Etymology.—The specific name is a noun in apposition taken from the type locality.

Diagnosis.—This species is most similar to *M. fierro*, but females can be distinguished by the small opening of the anterior epigynal

pouch; furthermore, the anterior tibiae usually bear 6 pairs of ventral spines (Fig. 32).

Female (holotype).—Total length 6.38. Carapace 2.80 long, 2.00 wide, wider on coxae III. Abdomen 3.88 long. Length of tibiae/metatarsi: I 1.92/1.58; II 1.70/1.44; III 1.44/1.48; IV 2.10/2.40. Palpal tarsus 0.94 long. Sternum 1.50 long. Spines as in *M. fierro*, but usually 2-2-2-2-0-2 ventral spines on tibia I. Color: light brown with brown spots and patches (Fig. 31), legs with brown spots at spine bases, and ventral spot lines on femora: one retrolateral on I and II, two on III, and one prolateral on IV; abdomen ventrally light, with short median band of brown spots. Epigynum with separate lateral lobes, median area elevated above anterior pouch, central depression deep, extended forward in central pouch (Fig. 33). Anterior pouch twofold, with conical cavities directed to each side (Fig. 34), accessory bulbs with ducts vertical to oblique.

Male.—Unknown.

Natural history.—Unknown.

Distribution.—Known from Córdoba and San Luis Provinces.

Other material examined.—ARGENTINA:

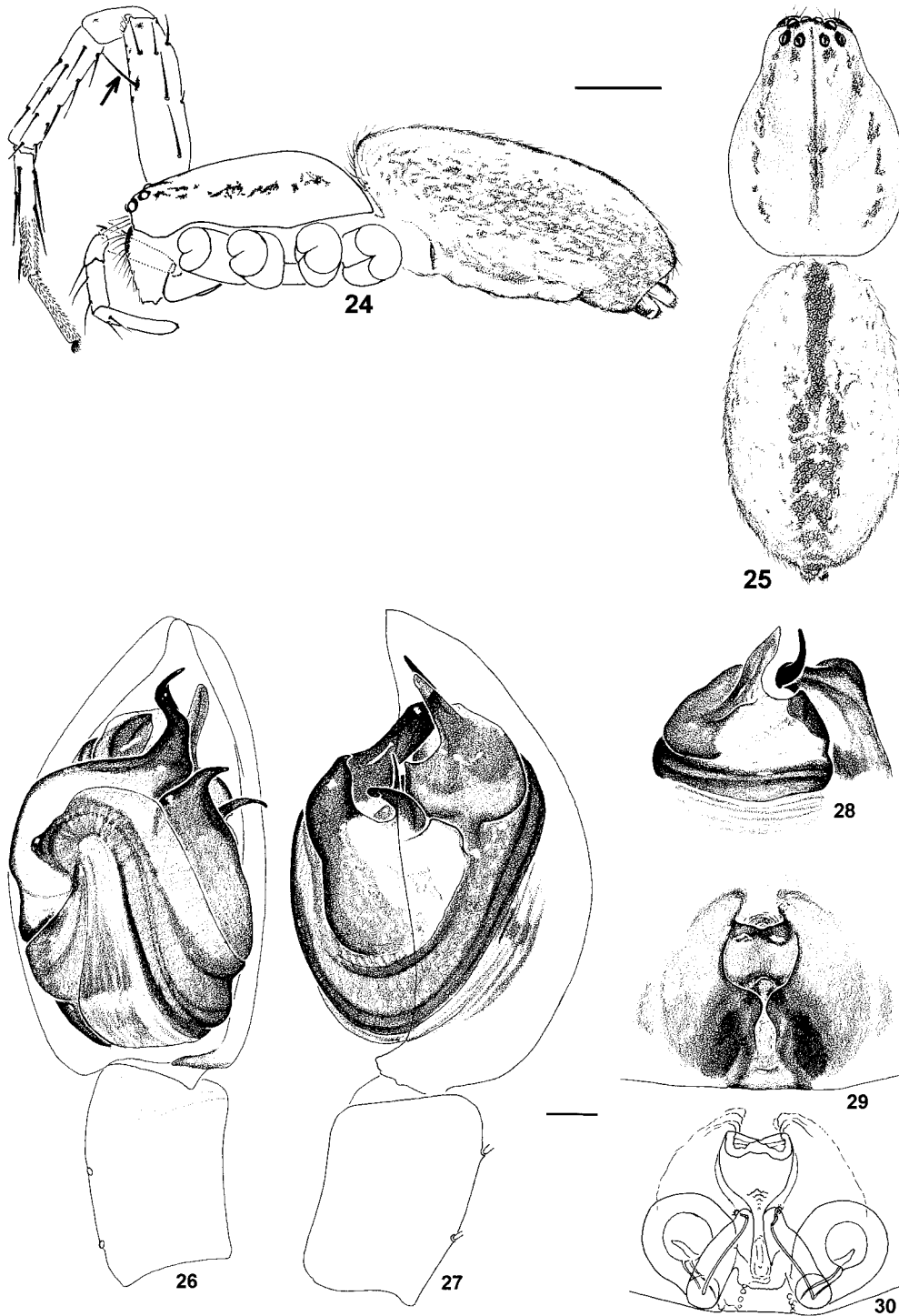

Figures 24–30.—*Monapia fierro* new species. 24, Female, lateral (arrow indicates prolateral/ventral spine on femur); 25, Female, dorsal; 26, Male palp, ventral; 27, Palp, retrolateral; 28, Palp, apical detail; 29, Epigynum, ventral; 30, Epigynum, cleared. Scales: Figs. 24–25 = 1 mm, Figs. 26–28 = 0.1 mm.

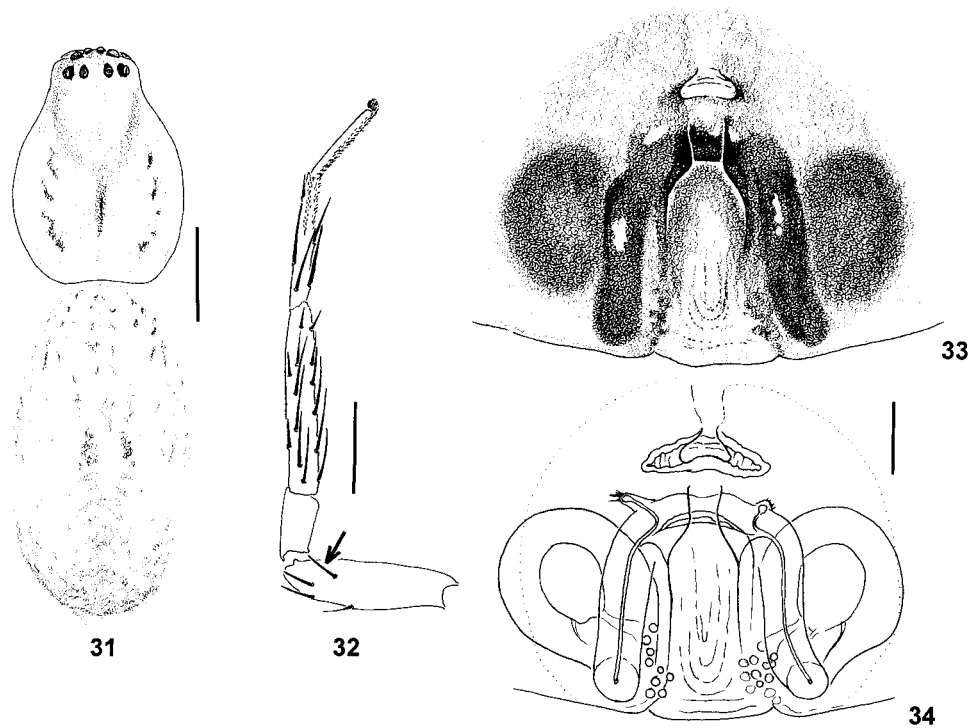

Figures 31–34.—*Monapia carolina* new species. 31, Female, dorsal; 32, Left foreleg (arrow indicates prolateral/ventral spine on femur); 33, Epigynum, ventral; 34, Epigynum, cleared. Scales: Figs. 31, 32 = 1 mm, Figs. 33, 34 = 0.1 mm.

Córdoba: La Cumbre, 8 November 1991, M. Ramírez, 1♀ (MACN); Pampa de Achala, El Cóndor, 20 November 1983, M.E. Galiano, 1♀ (MACN). *San Luis*: same locality as types, 3♀.

Monapia tandil new species
(Figs. 35–39)

Types.—Male holotype (MACN 9583) from Argentina, Buenos Aires Province, Tandil, no date, J.M. Viana.

Etymology.—The specific name is a noun in apposition taken from the type locality.

Diagnosis.—This species is closest to *M. vittata*, as both have a flat apical extension on the amaurobioidine paramedian apophysis, and can be easily distinguished from *M. vittata* by the thin median apophysis.

Male (holotype).—Total length about 5.60. Carapace 2.50 long, 1.80 wide, wider on coxae III. Abdomen badly preserved, about 3.10 long. Length of tibiae/metatarsi: I 3.46/3.03; II 2.73/2.30; III 1.97/1.70; IV 2.87/2.97. Spines: I: Femur d 1-1-1, p and r 0-1-1; tibia

v 2-2-2, p and r 1-1; metatarsus v 2bas, p and r 1, d 0-p1-2. II=I. III: Femur d 1-1-1, p 0-0-1-1-1, r 0-1-1; tibia v p1-2-2, p and r 1-1, d 0-1; metatarsus v2-p1-2, p and r d1-1-1, d 0-p1-2. IV: Femur d 1-1-1, p 1ap, r 0-1-1; patella r 1; tibia and metatarsus = III. Palp: Femur d 0-0-1-p3; patella d 1ap; tibia p 2-2, d 1-1; cymbium p 0-1-1. Color: light brown with brown pattern on carapace as in Fig. 35, legs with brown spots, tibiae III and IV darker, with two longitudinal light lines; sternum with one oval brown patch in front to each coxae I–III, and median longitudinal line; abdomen light gray, with brownish-violet anterior median patch, several inverted “V” through the median line, the three posterior darker, and a very dark patch upon the anal tubercle. Cymbium with slight retrolateral basal notch (Fig. 36). Copulatory bulb (Figs. 37–39) with paramedian apophysis short and thick, prolateral portion of secondary conductor without groove, displaced towards the base of embolus and bearing small denticles. There is a thin,

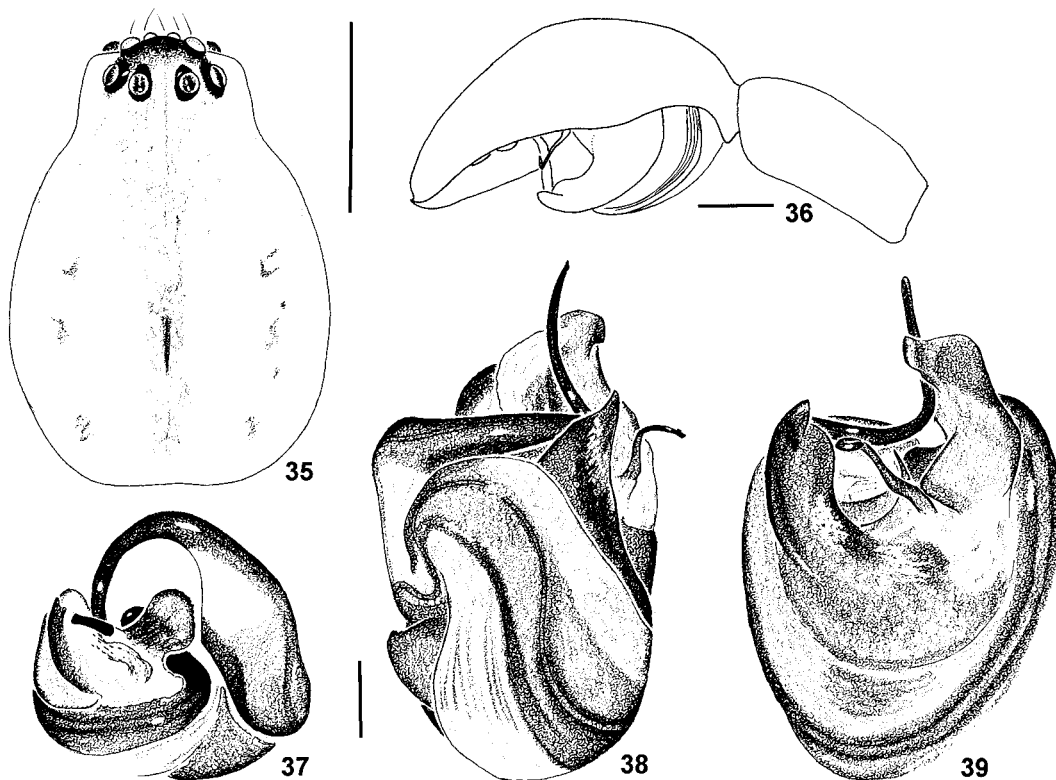

Figures 35–39.—*Monapia tandil* new species. 35, Male carapace; 36, Male palp, retrolateral; 37, Male palpal bulb, apical detail; 38, Palp, ventral; 39, Palp, retrolateral. Scales: Fig. 35 = 1 mm, Fig. 36 = 0.2 mm, Figs. 37–39 = 0.1 mm.

curved and pointed sclerite of uncertain homology arising behind the median apophysis.

Natural history.—Unknown.

Distribution.—Known only from type locality.

Other material examined.—None.

Monapia dilaticollis (Nicolet 1849)

Clubiona dilaticollis Nicolet 1849: 436.

M. dilaticollis, Ramírez 1995b: 78.

Additional records.—**CHILE:** REGION IX: Malleco: Río Blanco, Curacautín, 1–5 February 1959, L. Peña, 1 ♀ (IRSN I.G. 19736). *Unknown locality:* El Coigo, 1–10 October 1960, L. Peña, 1 ♀ (IG 19736, IRSN).

Monapia vittata (Simon 1884)

Tomopisthes vittatus Simon 1884: 135.

Monapia vittata, Ramírez 1995b: 81.

Additional records.—**ARGENTINA:** *Chubut:*

La Hoya, 42°54'S, 71°19'W, 16 November 88. V. & B. Roth, 5 ♀ (CAS).

Monapia lutea (Nicolet 1849)

Clubiona lutea Nicolet 1849: 429.

Monapia lutea, Ramírez 1995b: 86.

Additional records.—**ARGENTINA:** *Neuquén:* P. Nac. Lanín: 5 km E Hua Hum, 5 November 1981, Pucará, Nielsen & Karsholt, 5 ♂ 8 ♀ (ZMK); February 1963, S. Schajovskoy, 1 ♀ (MACN); November 1971, L. Yinoff, 1 ♀ (MACN); December 1973, S. Schajovskoy, 2 ♂ (MACN); San Martín de los Andes, 640 m, 17–31 October 1981, Nielsen & Karsholt, 2 ♂ (ZMK). *Río Negro:* Bariloche, 12–20 November 1981, Nielsen & Karsholt, 1 ♀ (ZMK); 810 m, 22 November 1978, Nielsen & Karsholt, 1 ♀ (ZMK); El Bolsón, 24 November 1962, Birabén, 6 ♂ 6 ♀ (MACN); February 1965, Birabén, 1 ♀ (MACN); *Chubut:* P. Nac. Lago Puelo, 220 m, 18 November 1978, Misión Científica Danesa, 1 ♂ (ZMK); Parque Nacional Los Alerces: March 1974, Bordon, 1 ♀ (MACN); Lago Futalaufquen, January 1990, M.J. Ramírez, 5 ♀ (MACN); Lago Menéndez,

Río Arrayanes, February 1986, M. Ramírez, 6 ♀ (MACN); Villa Futalaufquen, 9 February 1986, M. Ramírez, 1 ♀ (MACN). **CHILE: REGION VIII:** Concepción: Hualpén, 2 January 1989, M. Ramírez, 1 ♀ (MACN). **REGION IX:** Malleco: Fundo María Ester, 15 km W Victoria, 14 January 1989, M. Ramírez, 2 ♀ (MACN); Monumento Natural Contulmo, 12 January 1989, M. Ramírez, 1 ♀ (MACN). Unknown locality: El Coigo, 1–10 October 1960, L. Peña, 1 ♀ (IG 19736, IRSN); 36, 1 ♀ (IG 15.765, IRSN). **REGION X:** Valdivia: 18.20 km NW Neltume, 25 November 1988, V. & B. Roth, 1 ♀ (CAS). Osorno: P. Nac. Puyehue, Aguas Calientes, 40°44'S, 72°19'W, 1440 m, 5–7 December 1988, V. & B. Roth, 2 ♀ (CAS).

ACKNOWLEDGMENTS

All curators of institutions listed above are gratefully acknowledged for the loan of specimens. Helpful comments on versions of the manuscript were provided by María Elena Galiano, Pablo Goloboff, Petra Sierwald, James Berry, and two anonymous reviewers. Mirta Arriaga provided valuable help in the identification of grasses. Specimens were reared in laboratory by courtesy of María Elena Galiano, and maintained by Susana Ledesma. Patricia Sarmiento provided valuable assistance in scanning micrographs. Support for this project was provided by a graduate fellowship and EXO085 fund from the Universidad de Buenos Aires.

LITERATURE CITED

- Bremer, K. 1994. Branch support and tree stability. *Cladistics*, 10:295–304.
- Brescovit, A. D. 1997. Revisão de Anyphaeninae Bertkau a nível de gêneros na região neotropical (Araneae, Anyphaenidae). *Rev. Brasileira Zool.*, 13(1):1–187.
- Farris, J.S., V.A. Albert, M. Källersjö, D. Lipscomb & A.G. Kluge. 1996. Parsimony jackknifing outperforms neighbor-joining. *Cladistics*, 12:99–124.
- Gerschman de Pikelin, B.S. & R.D. Schiapelli. 1970. El género *Monapia* Simon 1897 (Araneae, Anyphaenidae). *Revta Mus. Argentino Cien. Nat., Zool.* 10(9):131–144.
- Goloboff, P.A. 1993. Estimating character weights during tree search. *Cladistics*, 9:83–91.
- Goloboff, P.A. 1995. Parsimony and weighting: a reply to Turner and Zandee. *Cladistics*, 11:91–104.
- Goloboff, P.A. 1996a. Pee-Wee version 2.5.1, program and documentation <<http://www.vims.edu/mess/hennig/hennig.html>>.
- Goloboff, P.A. 1996b. Nona version 1.5.1, program and documentation <<http://www.vims.edu/mess/hennig/hennig.html>>.
- Goloboff, P.A. 1997. Self-weighted optimization: Tree searches and character state reconstructions under implied transformation costs. *Cladistics*, 13:225–245.
- Lipscomb, D.L. 1992. Parsimony, homology and the analysis of multistate characters. *Cladistics*, 8:45–65.
- Mello-Leitão, C.F. 1944. Arañas de la provincia de Buenos Aires. *Rev. Mus. La Plata, Zool.* III:311–393.
- Nicolet, H. 1849. Arácnidos. III., Pp. 319–543, *In* Historia Física y Política de Chile. Zoología. (C. Gay, ed.). Paris.
- Ramírez, M.J. 1995a. A phylogenetic analysis of the subfamilies of Anyphaenidae (Arachnida, Araneae). *Entomol. Scandinavica*, 26:361–384.
- Ramírez, M.J. 1995b. Revisión y filogenia del género *Monapia* (Araneae, Anyphaenidae), con notas sobre otras Amaurobioidinae. *Boln. Soc. Biol. Concepción*, 66:71–102.
- Ramírez, M.J. 1997. Revisión y filogenia de los géneros *Ferrieria* y *Acanthoceto* (Araneae: Anyphaenidae, Amaurobioidinae). *Iheringia, Zool.*, (82):173–203.
- Sierwald, P. 1990. Note on a technique for cleaning female copulatory organs in spiders. *American Arachnol.*, 41:2.
- Simon, E. 1897. *Histoire Naturelle des Araignées*, 2(1). Paris, Librairie Encyclopédique de Roret. 192 pp.

Manuscript received 15 December 1997, revised 18 December 1998.